

# Area Gripping Systems FXP-60/FMP-60

Gripper width 60 mm



## Suitability for industry specific applications

### Application

- Universal gripper for handling workpieces of different sizes, geometries, materials and surfaces
- Handling of the workpieces from different pickup positions
- Handling of porous workpieces and workpieces with cutouts
- Suitable for fully automated applications



Area Gripping Systems FXP-60/FMP-60

### Design

- Aluminum base section (1) with lateral T-slots for sensors; different gripper lengths possible
- Connection pipe (2) for external vacuum generation or compressed air connection (3) for included multi-stage ejector
- Gauge (4)
- Sealing plate (5)

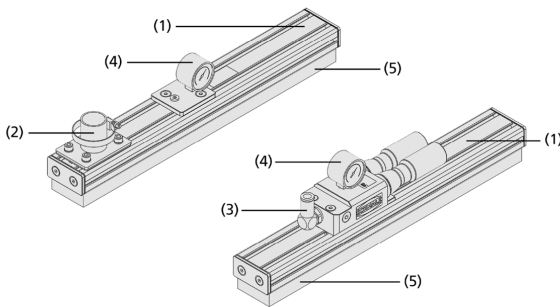

System design Area Gripping Systems FXP-60/FMP-60

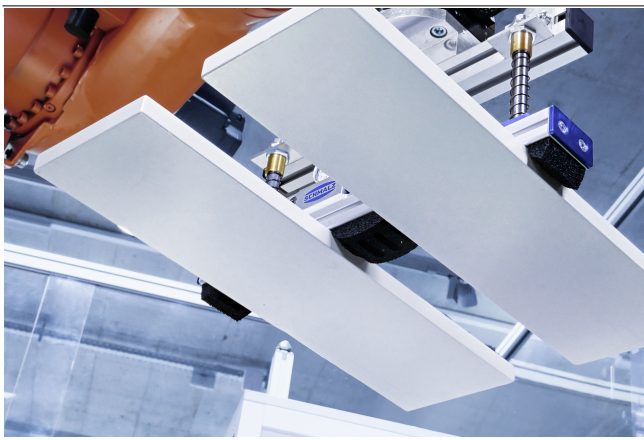

Area gripper FXP-60 when handling furniture panels

### Product highlights

- Slim area gripping system with 60 mm width enables use in confined work areas
- High effective lift capacity due to modular lightweight design
- Low operating costs with high operational reliability due to particularly energy-efficient vacuum generation (installed in FXP-60)
- High-performance sealing foam with excellent sealing and long service life
- Sealing foam with quick-change adhesive film for effortless replacement without time-consuming cleaning

# Area Gripping Systems FXP-60/FMP-60

Gripper width 60 mm

## Ordering data Area Gripping Systems FXP-60/FMP-60

Type	Part no.
FXP-60-SW70 442 1R18 O20	10.01.53.00070
FXP-60-SW70 1234 1R18 O20	10.01.53.00053
FMP-60-SW70 442 1R18 O20 G32	10.01.53.00071
FMP-60-SW70 1234 1R18 O20 G32	10.01.53.00027

## Ordering data Spare parts Area Gripping Systems FXP-60/FMP-60

Type (sealing foam)	Part no.
DI-PL 1,224	10.01.53.00032
DI-PL 432	10.01.53.00067

## Ordering data Accessories Area Gripping Systems FXP-60/FMP-60

Accessories	Part no.
Flexolink FLK G1/4-IG G1/4-AG	10.01.03.00178
Flexolink FLK G1/4-AG G1/4-AG	10.01.03.00152
Vacuum gauge VAM 40 V U BAR	10.07.02.00046
Solenoid valve EMVP 32 24V-DC 3/2 NO	10.05.02.00068
Spring plunger FSTE-HD G1/4-AG 50 VG	10.01.02.00876
Vacuum distributor VTR-SL 3x RST60 2xD32	10.01.43.00013
Flange plate FLAN-PL 50x54x10 AL-PUL FXP-FMP-60	10.01.53.00029
Mounting set SET FXP/FMP-60	10.01.53.00025

Spare parts	Artikelnummer Sealing plate (FXP/FMP-60)
FMP-60-SW70 1234 1R18 O20 G32	-
FXP-60-SW70 1234 1R18 O20	-
FXP-60-SW70 442 1R18 O20	-
FMP-60-SW70 442 1R18 O20 G32	-

## Technical data Area Gripping Systems FXP-60/FMP-60

Type	Arrangement	Material type	Number of suction cells	Air consumption [l/min]*	Suction rate (max.) [l/min]**	Suction force at -250 mbar [N]***	Required suction capacity for pu = -0.25 bar [l/min]****	Sealing element	Weight [kg]
FMP-60-SW70 1234 1R18 O20 G32	1R18	Foam O, Height 20 mm	67	-	-	433	176	Sealing Foam	3
FMP-60-SW70 442 1R18 O20 G32	1R18	Foam O, Height 20 mm	23	-	-	149	61	Sealing Foam	2
FXP-60-SW70 1234 1R18 O20	1R18	Foam O, Height 20 mm	67	300	425	433	-	Sealing Foam	3
FXP-60-SW70 442 1R18 O20	1R18	Foam O, Height 20 mm	23	165	270	149	-	Sealing Foam	2

\*Operating pressure 5 bar

\*\*Operating pressure 5 bar

\*\*\*The suction force specifications are theoretical values at -0.25 bar vacuum. The actual values may deviate. They are given without safety factors.

\*\*\*\*The external vacuum generator used must provide at least the specified suction volume at a vacuum of -0.25 bar (at the vacuum connection piece of the FMP).

# Area Gripping Systems FXP-60/FMP-60

Gripper width 60 mm

Design data Area Gripping Systems FXP-60/FMP-60

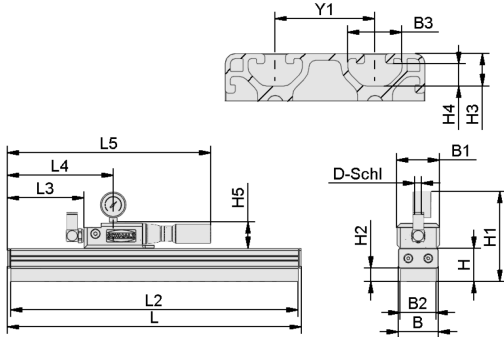

FXP-60

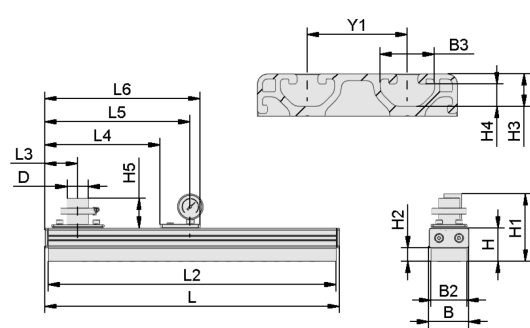

FMP-60

# Area Gripping Systems FXP-60/FMP-60

Gripper width 60 mm

## Design data Area Gripping Systems FXP-60/FMP-60

Type	B [mm]	B1 [mm]	B2 [mm]	B3 [mm]	D [mm]	H [mm]	H1 [mm]	H2 [mm]	H3 [mm]	H4 [mm]	H5 [mm]	L2 [mm]	L3 [mm]	L4 [mm]	L5 [mm]	L6 [mm]	Y1 [mm]
FXP-60-SW70 442 1R18 O20	60	64	54	16.3	-	50	102	20	9.75	6.75	45	432	115.0	159	306	-	30
FXP-60-SW70 1234 1R18 O20	60	64	54	16.3	-	50	102	20	9.75	6.75	45	1,224	115.0	159	403	-	30
FMP-60-SW70 442 1R18 O20 G32	60	-	54	16.3	32	50	102	20	9.75	6.75	45	432	49.5	173	218	233	30
FMP-60-SW70 1234 1R18 O20 G32	60	-	54	16.3	32	50	102	20	9.75	6.75	45	1,224	49.5	173	218	233	30

## Multimedia product presentation

Medium	Link
Product video	<a href="https://vimeo.com/793034865">https://vimeo.com/793034865</a> <a href="https://vimeo.com/147433631">https://vimeo.com/147433631</a>